

72

EASTERN UNIVERSITY, SRI LANKA
FIRST EXAMINATION IN SCIENCE – 2010/2011



FIRST SEMESTER (PROPER/REPEAT)

OCTOBER/NOVEMBER 2012

PH 105 GENERAL PHYSICS

Time: 01 hour

Answer ALL Questions

1. Explain what is meant by the term “streamline” in describing fluid flow. Show that for a laminar flow, the rate of flow Q of fluid through a pipe of radius r and length l , subject to a pressure difference p is given by Poisuille's equation:

$$Q = \frac{\pi p r^4}{8 \eta l}$$

where η is the viscosity of the fluid. State clearly the assumptions made necessary to derive the Poisuille's equation.

Figure 1 shows a needle syringe contains $1.0 \times 10^{-6} \text{ m}^3$ of a solution with a viscosity of $1.5 \times 10^{-3} \text{ Pa}$. The syringe has a cross sectional area of $8.0 \times 10^{-5} \text{ m}^2$. The length and inner radius of the needle are 0.025 m and $4.0 \times 10^{-4} \text{ m}$ respectively. The gauge pressure in the vein is 1900 Pa . What force must be applied to the syringe in order to inject the entire solution into a vain in 3 seconds?

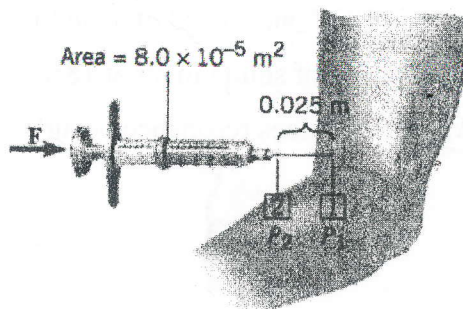

Figure 1

2. Distinguish between “constructive interference” and “destructive interference” in linear superposition of sound waves. What are the conditions for constructive and destructive interference?

(a) Two loudspeakers separated by a distance of 3.20 m are vibrating in phase with the same tone, as shown in Figure 2. A person listens from a location 2.40 m directly in front of the loudspeaker B. The speed of sound in air is 343 m/s. What is the lowest frequency that will produce destructive interference to the person at point C?

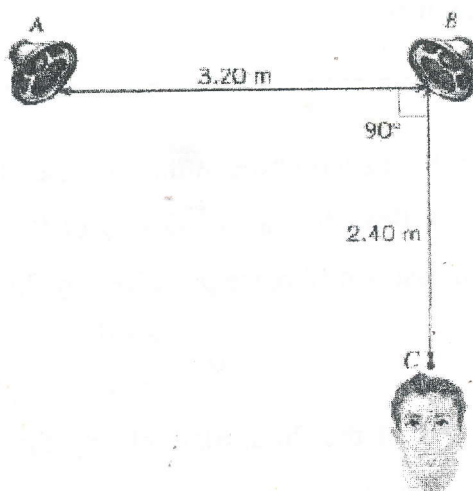

Figure 2

(b) A thin hollow tube of length 1.00 m is inserted vertically into a tall container of water. A tuning fork with frequency of 520.0 Hz is struck and held near the top of the tube as the tube is slowly pulled up and out of the water. At certain distances (L) between the top of the tube and the water surface, resonance occurs. The temperature of the air in the tube is 18°C, and speed of sound in air at 0°C is 331.3 m/s.

- i. Calculate the speed of sound in air at 18°C.
- ii. At what values of L does resonance occur?