

EASTERN UNIVERSITY, SRI LANKA
FIRST YEAR FIRST SEMESTER EXAMINATION IN AGRICULTURE - 2004/2005.
AEN 1102 ENGINEERING DRAWING (1:00/30)
(PRACTICAL)

Answer all questions

Time: Two hours

1. Sketch the first angle orthographic projections for an isometric view is given below.

(20 marks)

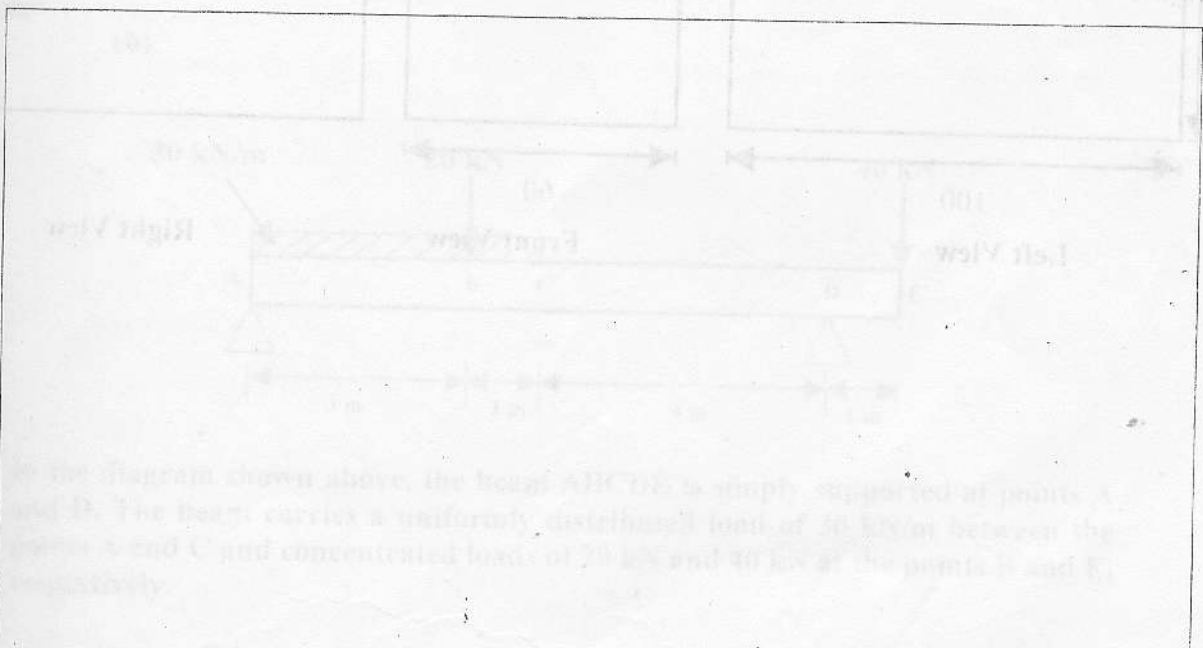
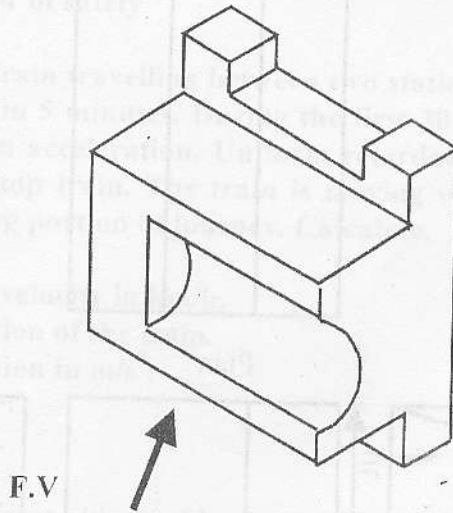

2. Draw the isometric view of the third angle orthographic projection is given below. Use the drawing sheet and instruments provided on the drawing board.

(All dimensions are in cm)

(80 marks)



Plan

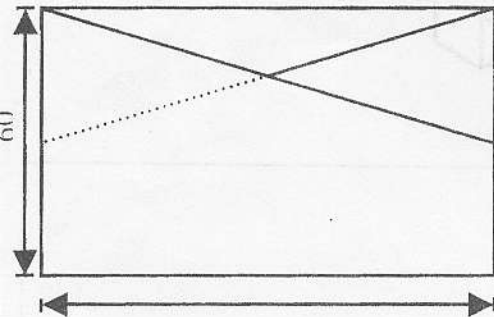

Left View

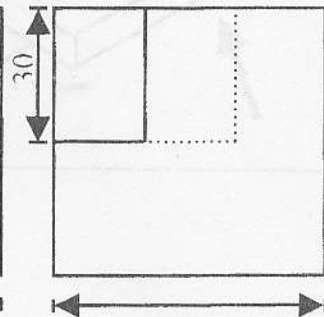

Front View

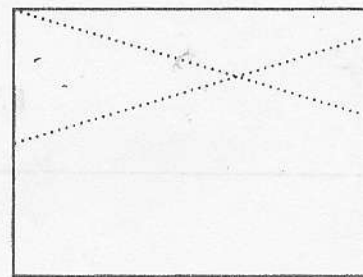

Right View